

SEMICONDUCTOR HEATER

HG 140 | 15 W to 150 W



- > Pressure clamp connectors
- > Dynamic heating up
- > Wide voltage range
- > Energy saving
- > Clip fixing
- > Quick installation

These heaters are used in enclosures where damage from condensation must be prevented, or where the temperature may not fall below a minimum value. The aluminium profile heater body design has a chimney effect and distributes the heat evenly. The heaters are designed for permanent operation. Pressure clamp connectors save time and simplify installation.

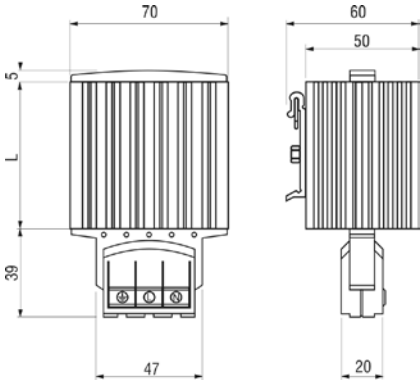

TECHNICAL DATA

Operating voltage	AC/DC 120 – 240 V ¹ (min. 110 V, max. 265 V)
Heating element	PTC resistor – temperature limiting
Heater body	extruded aluminium profile, anodised
Connection	3 pressure clamps for stranded wire 0.5 – 1.5 mm ² (with wire end ferrule) and rigid wire 0.5 – 2.5 mm ²
Connection casing	plastic according to UL94 V-0, black
Mounting	clip for 35 mm DIN rail, EN 60715
Fitting position	vertical airflow (air outlet up, connection on bottom)
Operating/Storage temperature	-45 to +70 °C (-49 to +158 °F)
Operating/Storage humidity	max. 90 % RH (non-condensing)
Protection type/Protection class	IP20 / I (earthed)
Approvals	VDE, UL File No. E150057, EAC
Accessoires	screw fixing, Art. No. 09024.0-00 (1 packing unit = 2 pieces)
Note	other voltages on request

¹ Operating with voltages below AC/DC 140 V reduces heating performance by approx. 10 %.

Art. No.	Heating capacity ²	Inrush current max.	Recommended pre-fuse T (time-delay)	Length (L)	Weight (approx.)
14000.0-00	15 W	1.5 A	2.0 A	65 mm	0.3 kg
14001.0-00	30 W	3.0 A	4.0 A	65 mm	0.3 kg
14003.0-00	45 W	3.5 A	4.0 A	65 mm	0.3 kg
14005.0-00	60 W	2.5 A	4.0 A	140 mm	0.4 kg
14006.0-00	75 W	4.0 A	6.3 A	140 mm	0.5 kg
14007.0-00	100 W	4.5 A	8.0 A	140 mm	0.5 kg
14008.0-00	150 W	9.0 A	10.0 A	220 mm	0.7 kg

² at +20 °C (+68 °F) ambient temperature