

Part number: **I18000012** Model: **SI18-AE8 NO**

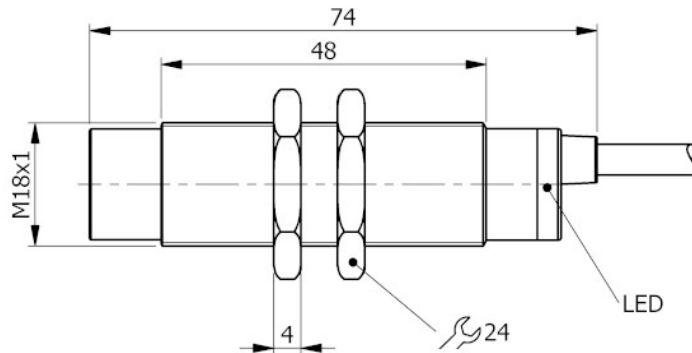

Dimension in mm

1. TECHNICAL CHARACTERISTICS



Electrical data		
Power supply type:		Alternating current
Working voltage:	[V]	20 ÷ 250
Protection class:		III
Outputs		
Function:		NO
Max voltage drop:	[V]	< 6
Max output current:	[mA]	300
Minimum output current:	[mA]	5
Max peak current:	[A]	1.5
Residual current:	[mA]	< 1
Max switching frequency:	[Hz]	12
Detection zone		
Switching distance-Sn:	[mm]	8
Real sensing distance-Sr:	[mm]	8 ±10%
Operative distance-So:	[mm]	0 ÷ 6.48
Accuracy and Deviations		
Correction factor:		Stainless steel: 0.9 - Brass: 0.5 - Aluminium: 0.4 - Copper: 0.4
Hysteresis:	[%Sr]	< 10
Switching point drift:	[%Sr]	-10 ÷ +10
Repeatability:	[%Sn]	< 3
Environmental conditions		
Temperature limits:	[°C]	-25 ÷ +70
IP rating:		IP65-IP66-IP67
Display and control elements		
Display:		Output switching status - 1 x LED: Yellow

Mechanical data

Housing:		Threded type
Thread designation:		M18x1
Dimensions:	[mm]	M18x1 - L=74.5
Materials:		Housing: Nickel-plated brass - Sensing area: POM blue - Lock nuts: Nickel-plated brass
Mounting:		Not embeddable
Weigth:	[g]	130

Electrical connection

Cable:		2 m - PVC/PVC - 2 x 0.50 mm ²
--------	--	--

Compliance to Standards / Directives

Directives compliance:		2014/30/EU -Electromagnetic compatibility directive (EMC) 2014/35/UE -Low voltage directive (LVD)
Standards compliance:		EN60947-5-2 - Product standard

2. NORME DI INSTALLAZIONE

WIRING DIAGRAM

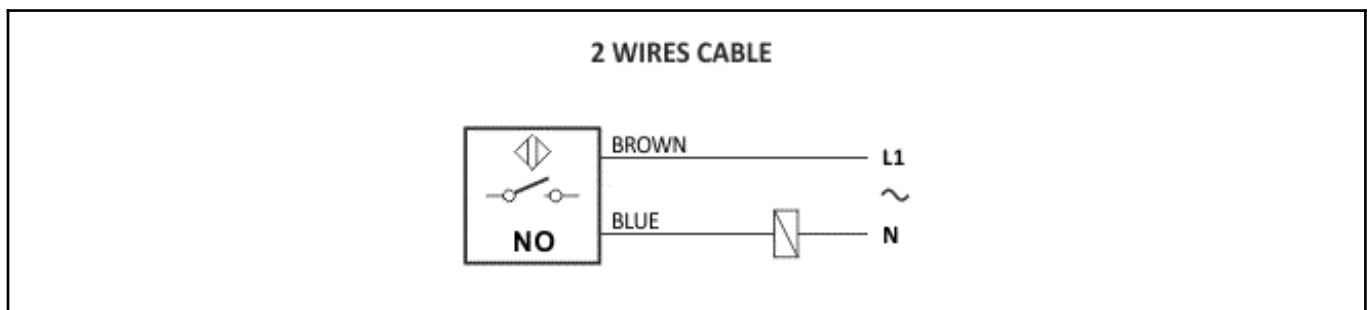

INSTRUCTIONS FOR CORRECT INSTALLATION

