

TEMPERATURE CONTROLLER MOUNTED ON A 35 mm RAIL RE60 TYPE



APPLICATION

The RE60 controller controls the temperature in objects through turning on and off the electrical controlling device according to the defined setting by the controller. It cooperates directly with RTD and TC. It is destined for the temperature control in telecommunication cabinets in food and drying industries and everywhere, where there is the necessity to stabilize the temperature changes. The controller has one output destined for the control and two alarm outputs.

TECHNICAL DATA

Input signals acc. table 1

Input signals and measuring ranges for inputs Table 1

Sensor type/inputs	Marking	Range [°C]	Basic error [°C]
Pt100 acc.to EN 60751	Pt100	-50...100	0.8
Pt100	Pt100	0...250	1.3
Pt100	Pt100	0...600	3.0
Fe-CuNi acc.to EN 60584-1	J	0...250	3.0
Fe-CuNi	J	0...600	4.0
Fe-CuNi	J	0...900	5.0
NiCr-NiAl acc. to EN 60584-1	K	0...600	4.0
NiCr-NiAl	K	0...900	5.0
NiCr-NiAl	K	0...1300	6.0
PtRh10-Pt acc. to EN 60584-1	S	0...1600	7.0

Current flowing through Pt100	< 220 μ A
Measurement time	0.5 s
Detection of error in the measuring circuit:	
- thermocouple, Pt100	overflow of the measuring range
Kinds of outputs:	
- relay	voltageless make contacts maximal load: voltage: 250 V a.c., 150 V d.c. current: 5 A 250 V a.c., 5 A 30 V d.c. resistance load: 1250 VA, 150 W
- logic voltage (without isolation from the sensor side)	voltage 5 V resistance limiting the current: 66 Ω
Way of output operation:	
- reverse for heating	
- direct for cooling	
Signalling:	
- active output	symbol on the LCD display
- active alarm	symbol on the LCD display and LED diode
Rated operating conditions:	
- supply voltage	230 V a.c. \pm 10%
110 V a.c. \pm 10%	
24 V a.c. \pm 10%	
18...72 V d.c.	
- frequency of supply voltage	50/60 Hz
- ambient temperature	0...23...50°C
- storage temperature	- 20...+70°C
- related air humidity	< 85% (without condensation)
- external magnetic field	< 400 A/m
- preheating time	30 min
- work position	any
Power consumption	< 3 VA
Dimensions	45 x 120 x 100 mm
Weigh	< 0,3 kg
Fixing	on a 35 mm rail
Protection degree ensuring by the house	IP 40 acc. to EN 60529
Additional errors in rated operating conditions:	
- changes of the ambient temperature	\leq 100% of the basic error /10 K.
Security requirements acc. to EN 61010-1	
- installation category	III
- pollution level	2
- maximal phase-to-earth working voltage:	
- for the supplying circuit, outputs	300 V
- for input circuits	50 V
Electromagnetic compatibility:	
- immunity acc. to EN 61000-6-2	
- emissions acc. to EN 61000-6-4	

CONTROLLER INSTALLATION

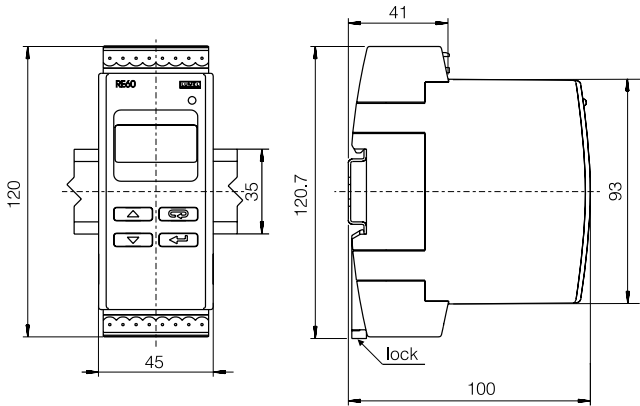

Fig. 1. Dimensions and fixing way of the controller

ELECTRICAL CONNECTIONS

Carry out electrical connections to the terminal strips and next insert strips into controller sockets.

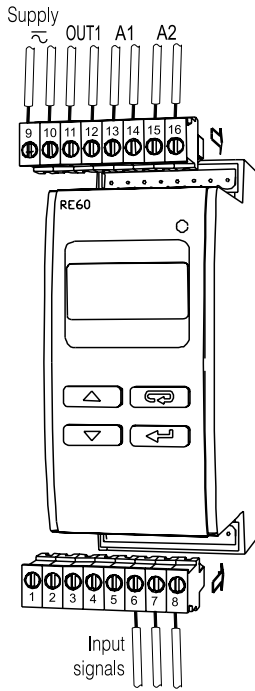

Fig. 2. View of controller connection strips

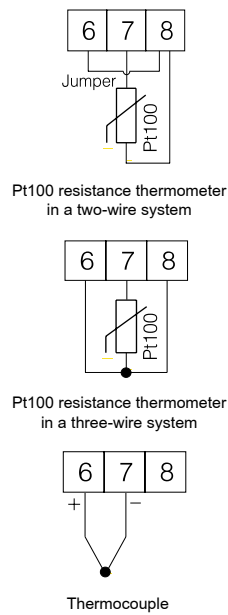

Fig. 3. Connection of input signals

ORDERING CODES

Kinds of versions and ordering codes

Table 2

Temperature controller RE60 -	XX	X	X	X	X
Input:					
resistance thermometer Pt100 (-50...100 °C)	01				
resistance thermometer Pt100 (0...250 °C)	02				
resistance thermometer Pt100 (0...600 °C)	03				
thermocouple J (0...250 °C)	04				
thermocouple J (0...600 °C)	05				
thermocouple J (0...900 °C)	06				
thermocouple K (0...600 °C)	07				
thermocouple K (0...900 °C)	08				
thermocouple K (0...1300 °C)	09				
thermocouple S (0...1600 °C)	10				
as per order	XX				
Main output:					
relay	1				
logic 0/5 V for SSR control	2				
as per order	X				
Alarm outputs:					
without outputs	0				
1 relay output	1				
2 relay outputs	2				
as per order	X				
Supply:					
230 V a.c. 50/60 Hz	1				
110 V a.c. 50/60 Hz	2				
24 V a.c. 50/60 Hz	3				
18...72 V d.c.	4				
as per order	X				
Additional requirements:					
without additional requirements	8				
with an extra quality inspection certificate	7				
acc. to agreement with the user*	X				

*The code number is established by the manufacturer.

ORDERING EXAMPLE

The **RE60 - 05 - 1 - 2 - 3 - 8** code means:
RE60 - temperature controller of RE60 type to be mounted on a 35 mm rail
05 - input: thermocouple J
1 - main output: relay
2 - alarm outputs: two relays
3 - supply: 24 V a.c. 50/60 Hz
8 - without additional quality inspection requirements

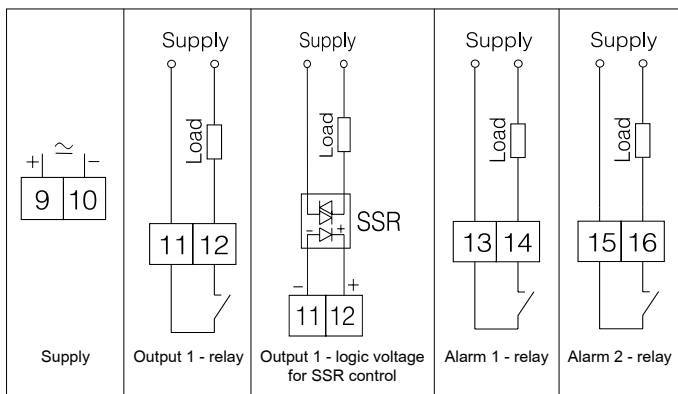

Fig. 4. Connection of the supply and load circuit