



**RAYCHEM**

## CCE-03-CR

Cold Lead Connection and End Seal Kit

Anschlussgarnitur Für Zuleitungskabel Und  
Endabschlussgarnitur

Kit De Liaison Froide ET D'extrémité

Aansluiting- En Eindafwerkingset

Kaldkabelskjøt OG Endeavslutningssett

Kalkabelanslutning Och Ändavslutningsatts

Kold Monteret Endeafslutning

Jatkospakkaus Kylmäkaapeliin Ja Loppupääte Kit  
Di Connessione E Terminazione

Zestaw Połączeniowy Z Przewodem

Zasilającym Oraz Zestaw Końcowy

Набор Для Подключения И Оконцевания  
Греющего Кабеля

Souprava Pro Připojení A Ukončení  
Samoregulačního Kabelu

Hideg-Vég Csatlakoztató És Véglezáró Készlet

Priključak Hladnog Kraja I Završna Garnitura

**EAC**

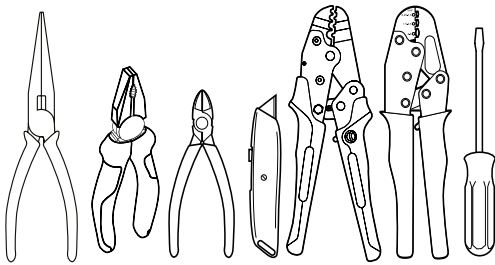

**B**

CT-100

CTL-05

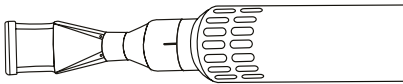
**C**

Frostop Black

H312/322

H612/622

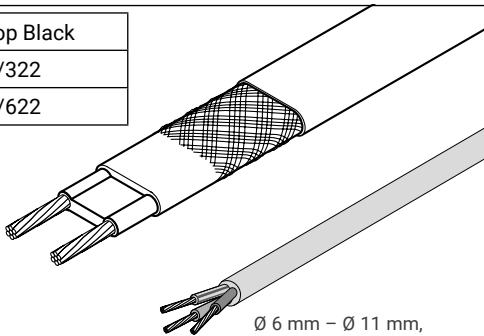

Ø 6 mm - Ø 11 mm,  
3 x 1,5 mm<sup>2</sup> - 3 x 2,5 mm<sup>2</sup>  
flame retardant

A

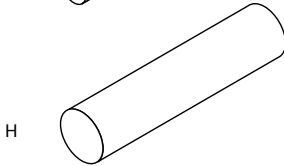
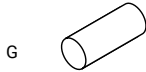
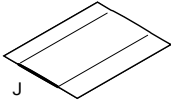
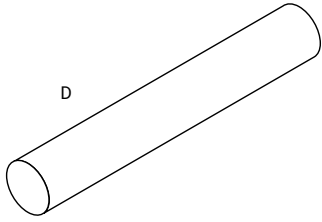
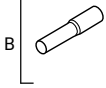
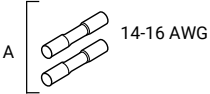

## ENGLISH

### A. KIT CONTENTS

|       |                              |
|-------|------------------------------|
| A,B   | Crimps                       |
| C,D,F | Cold lead shrinkable sleeves |
| G,H,  | End seal shrinkable sleeves  |
| J     | Mastic                       |

## SVENSKA

### A. Satsinnehåll

|       |                                |
|-------|--------------------------------|
| A,B   | Presshylsor                    |
| C,D,F | Krympslangar för kallkabel     |
| G,H,  | Krympslangar för ändavslutning |
| J     | Mastik                         |

## DEUTSCH

### A. INHALT DER GARNITUR

|       |                                       |
|-------|---------------------------------------|
| A,B   | Pressverbinder                        |
| C,D,F | Schrumpfschläuche für Zuleitungskabel |
| G,H,  | Schrumpfschläuche für Endabschluss    |
| J     | Abdichtmasse                          |

## DANSK

### A. Komponentliste

|       |                               |
|-------|-------------------------------|
| A,B   | Terminaler                    |
| C,D,F | Krympemuffe for kold kabel    |
| G,H,  | Krympemuffe for endeaflutning |
| J     | Mastik                        |

## FRANÇAIS

### A. CONTENU DU KIT

|       |   |
|-------|---|
| A,B   | Manchons à sertir                             |
| C,D,F | Manchons thermo-rétractables pour liaison     |
| G,H,  | Manchons thermo-rétractables pour l'extrémité |
| J     | Mastic  |

## SUOMI

### A. Pakkaus sisältää

|       |                               |
|-------|-------------------------------|
| A,B   | Liittimet                     |
| C,D,F | Kutistemuovit kylmäkaapelille |
| G,H,  | Kutistemuovit loppupääteeseen |
| J     | Tiiviste                      |

## NEDERLANDS

### A. Inhoud kit

|       |                                |
|-------|--------------------------------|
| A,B   | Krimpverbinders                |
| C,D,F | Krimpkousen voor aansluiting   |
| G,H,  | Krimpkousen voor eindafwerking |
| J     | Mastiek                        |

## ITALIANO

### A. Contenuto del kit

|       |  |
|-------|--|
| A,B   | Connettori                               |
| C,D,F | Termorestringenti per lato alimentazione |
| G,H,  | Termorestringenti per lato finale        |
| J     | Mastice                                  |

## NORSK

### A. Settet inneholder

|       |                                  |
|-------|----------------------------------|
| A,B   | Presshylser                      |
| C,D,F | Krympestrømper til kaldkabel     |
| G,H,  | Krympestrømper til endeaflutning |
| J     | Mastic                           |

## POLSKI

### A. ZAWARTOŚĆ ZESTAWU

|       |  |
|-------|--|
| A,B   | Tulejki zaciskowe                                    |
| C,D,F | Rurki termokurcziwe do połączenia z przewodem zimnym |
| G,H,  | Rurki termokurcziwe zestawu końcowego                |
| J     | Mastyka  |

## ENGLISH

Heating cable:  
nVent RAYCHEM CCE-03-CR  
Applicable to heating  
cables nVent RAYCHEM  
FroStop

Cold lead cable:  
overall diameter:  
6 mm - 11 mm.  
conductor size:  
3 x 1,5 mm<sup>2</sup> or 3 x 2,5 mm<sup>2</sup>

**WARNING:** Please make sure  
the installation is carried out  
in clean, dry conditions and all  
cable ends are protected from  
moisture.

## DEUTSCH

Heizleitung:  
nVent RAYCHEM CCE-03-CR  
Zur Verwendung mit  
Heizleitung FroStop

Zuleitungskabel:  
Aussendurchmesser:  
6 mm - 11 mm.  
Leiterquerschnitt:  
3 x 1,5 mm<sup>2</sup> oder 3 x 2,5  
mm<sup>2</sup>

**ACHTUNG:** Bitte stellen Sie  
sicher, dass die Montage  
in sauberer und trockener  
Umgebung erfolgt und die  
Kabelenden vor Feuchtigkeit  
geschützt werden.

## FRANÇAIS

Ruban chauffant:  
nVent RAYCHEM CCE-03-CR  
Compatible avec les  
rubans chauffants FroStop

Câble de liaison froide:  
diamètre extérieur:  
6 mm - 11 mm  
Sections des conducteurs:  
3 x 1,5 mm<sup>2</sup> ou 3 x 2,5 mm<sup>2</sup>

**Attention:** Veiller à ce que  
l'installation soit réalisée dans  
un environnement propre et  
sec et que les extrémités du  
ruban soient protégées de  
l'humidité.

## NEDERLANDS

Verwarmingskabel:  
nVent RAYCHEM CCE-03-CR  
Toepasbaar op de  
verwarmingskabels  
FroStop

Aansluitkabel:  
buitendiameter:  
6 mm - 11 mm.  
stroomdraadafmeting:  
3 x 1,5 mm<sup>2</sup> of 3 x 2,5 mm<sup>2</sup>

**OPGELET:** De installatie moet  
worden uitgevoerd in droge  
en zuivere omstandigheden,  
en de kabeluiteinden moeten  
altijd tegen vocht beschermd  
worden.

## NORSK

Varmekabel:  
nVent RAYCHEM CCE-03-CR  
Til bruk for FroStop

Kaldkabel:  
utvendig diameter:  
6 mm - 11 mm  
ledertverrsnitt:  
3 x 1,5 mm<sup>2</sup> eller  
3 x 2,5 mm<sup>2</sup>

Advarsel: Utfør installasjonen under rene og tørre forhold, og forsikre at kabelendene ikke utsettes for fuktighet.

## SVENSKA

Värmekabel:  
nVent RAYCHEM CCE-03-CR  
Passar till FroStop

Kalkabel:  
ytterdiameter:  
6 mm - 11 mm  
ledararea:  
3 x 1.5 mm<sup>2</sup> eller 2.5 mm<sup>2</sup>

Varning: Säkerställ att installationen sker under rena, torra förhållanden och att värmekabeländarna skyddas mot fukt.

## DANSK

Varmekabel:  
nVent RAYCHEM CCE-03-CR  
FroStop

Kold kabel:  
Udvendig diameter:  
6 mm - 11 mm.  
Tilslutning:  
3 x 1,5 mm<sup>2</sup> eller  
3 x 2,5 mm<sup>2</sup>

Advarsel: Sørg for at montagen sker under rene og tørre forhold, samt at alle enderne på kablerne beskyttes mod fugt. Læs hele montagevejledningen inden arbejdet påbegyndes og følg instruktionerne nøje.

## SUOMI

nVent RAYCHEM CCE-03-CR  
soveltuu lämpökaapeille:  
FroStop

Kylmäkaapeli:  
kokonaishalkaisija:  
6 mm -11 mm  
johtimen koko:  
3 x 1,5 mm<sup>2</sup> tai 3 x 2,5 mm<sup>2</sup>

Varoitus: Varmista että asennus tehdään puhtaissa, kuivissa olosuhteissa ja kaapelin päät on suojattu kosteudelta.

## ITALIANO

Cavo scadante:  
nVent RAYCHEM CCE-03-CR  
Adatto ai cavi scaldanti ai  
FroStop

Cavo di potenza:  
diametro esterno:  
6 mm - 11 mm.  
dimensione del conduttore:  
3 x 1,5 mm<sup>2</sup> o 3 x 2,5 mm<sup>2</sup>

Attenzione: Assicurarsi che l'installazione venga effettuata in ambiente asciutto E, pulito E che tutte le terminazioni dei cavi siano protette dall'umidità.

## POLSKI

Przewód grzejny:  
nVent RAYCHEM CCE-03-CR  
Do stosowania z  
przewodami  
grzejnymi FroStop

Przewody zasilające (zimne)  
wymiary zewnętrzne:  
6 mm - 11 mm  
średnica żyły:  
3 x 1,5 mm<sup>2</sup> lub  
3 x 2,5 mm<sup>2</sup>

UWAGA: Montaż należy wykonywać w miejscu czystym, suchym, a końce przewodu grzejnego chronić przed wilgocią.

## РУССКИЙ

Применение:  
nVent RAYCHEM CCE-03-CR  
Применяется для  
греющих кабелей  
FroStop

Силовой кабель  
Внешний диаметр:  
6 мм-11 мм  
Сечение жилы:  
3 x 1,5 мм<sup>2</sup> или 3 x 2,5 мм<sup>2</sup>

ВНИМАНИЕ: монтаж должен производиться в чистых, сухих условиях; греющий кабель должен храниться с защищенными от влаги концами.

## ČESKY

Topný kabel:  
nVent RAYCHEM CCE-03-CR  
Souprava je určena pro  
topné kabely  
FroStop

Napájecí kabel:  
Vnější průměr:  
6 mm - 11 mm.  
průřez vodiče:  
3 x 1,5 mm<sup>2</sup> nebo  
3 x 2,5 mm<sup>2</sup>

UPOZORNĚNÍ: Zajistěte, aby montáž byla prováděna v čistém a suchém prostředí, všechny konce kabelů chraňte před vniknutím vlhkosti.

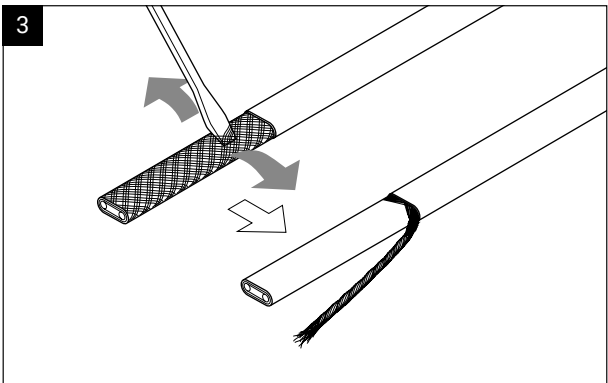
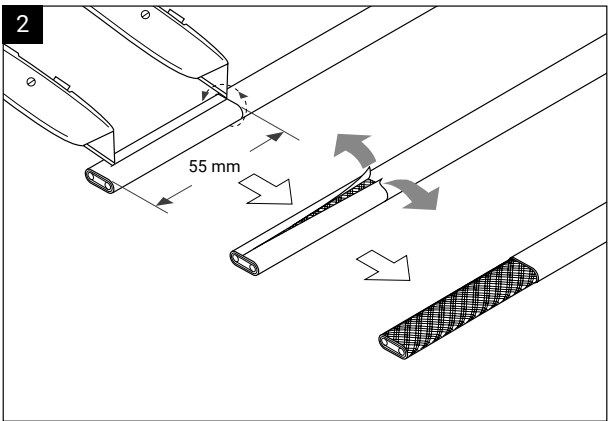
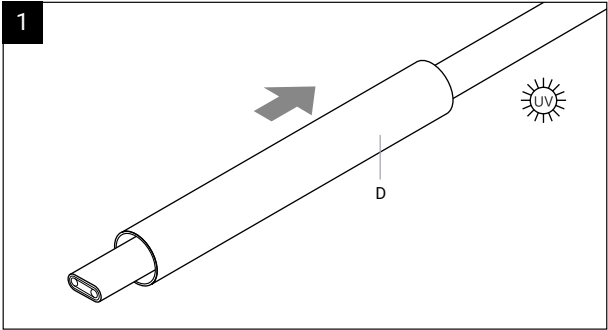



4

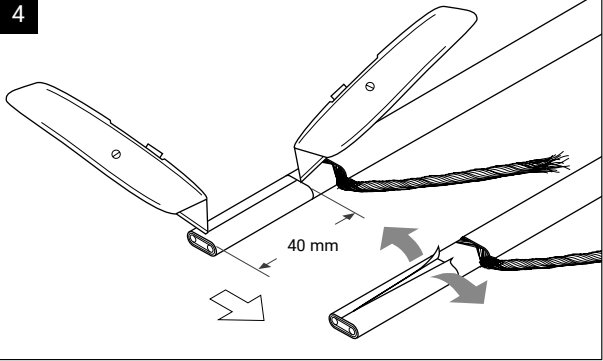

5

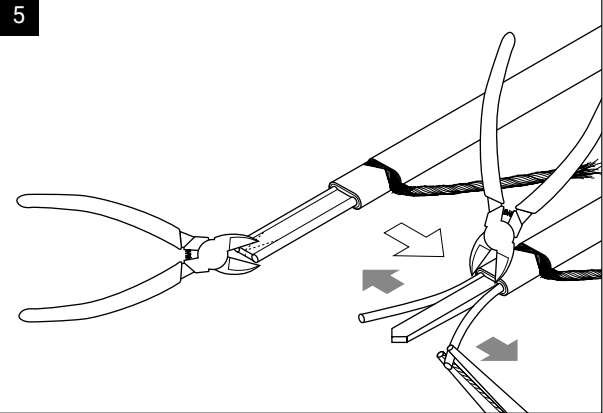

6

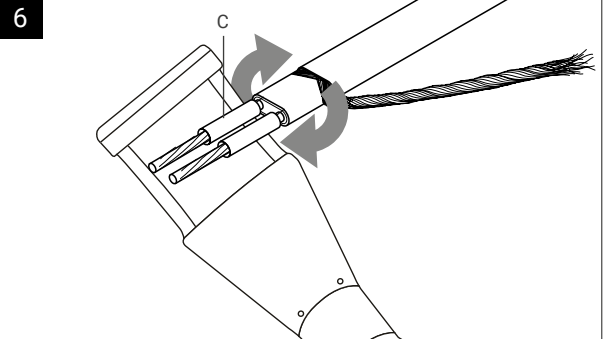

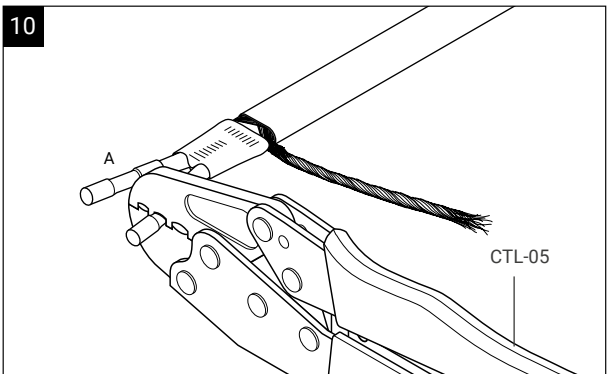
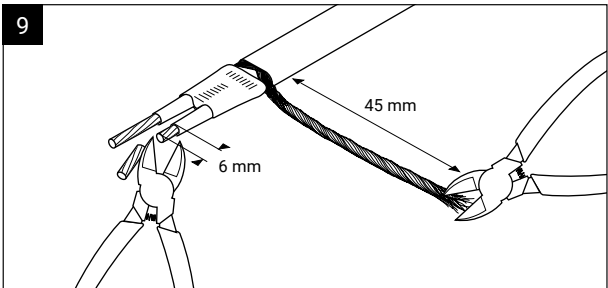
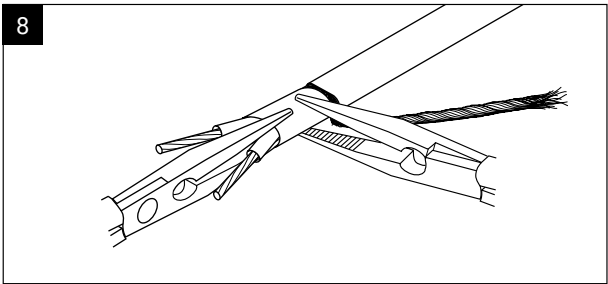
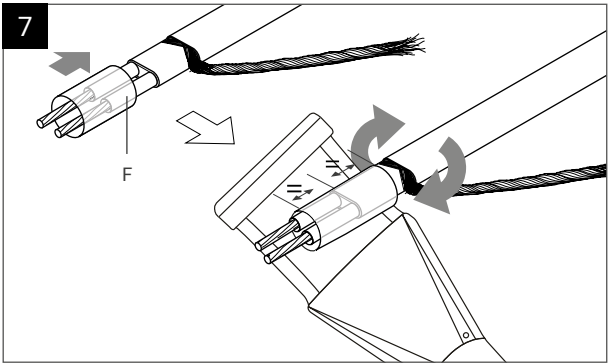

11

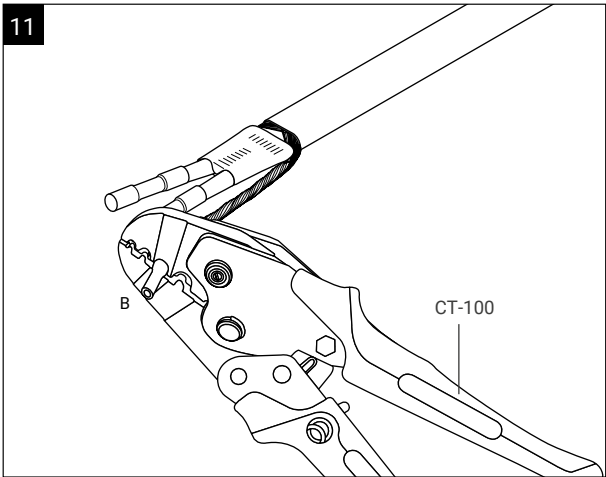

12

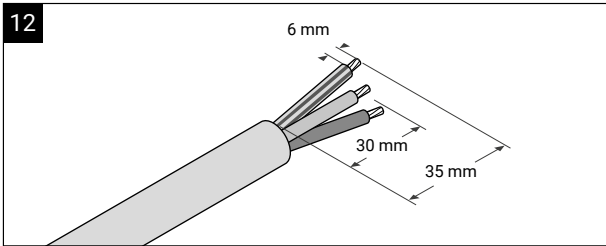

13A

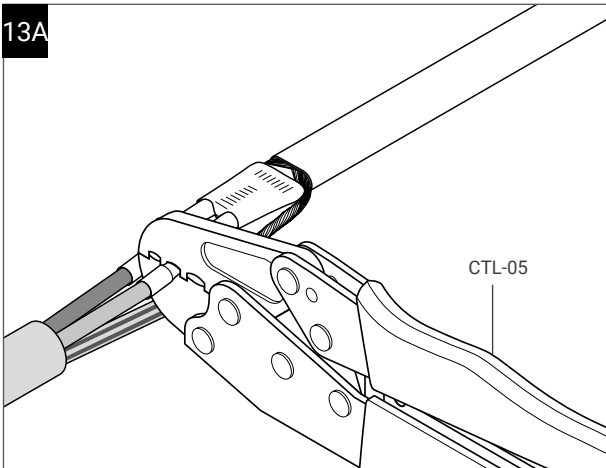

13B

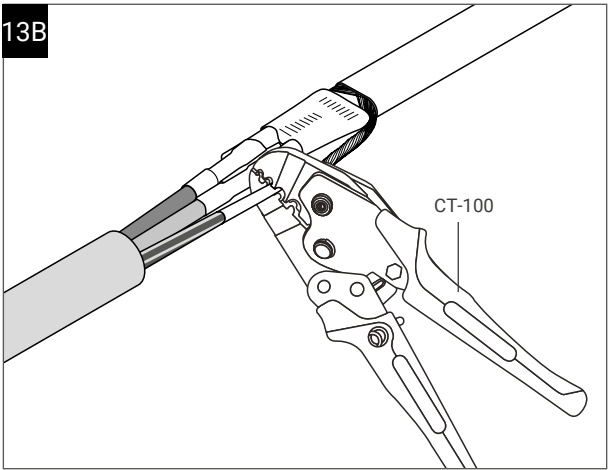

14

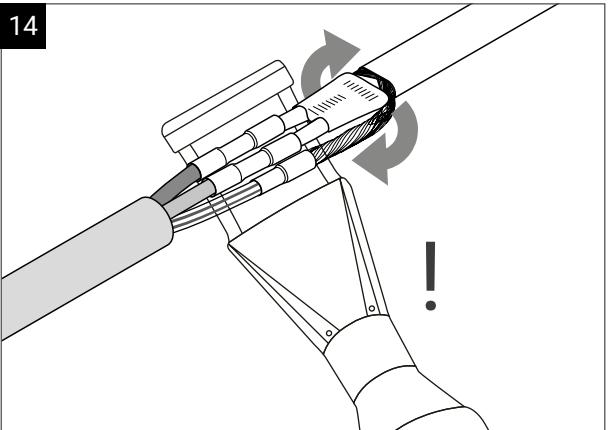

15

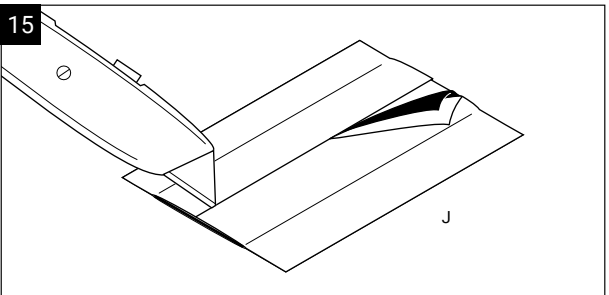

16

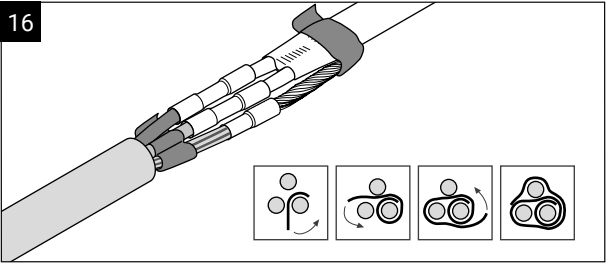

17

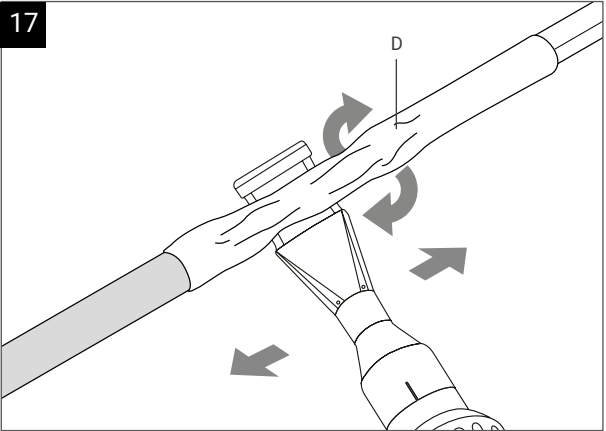

18

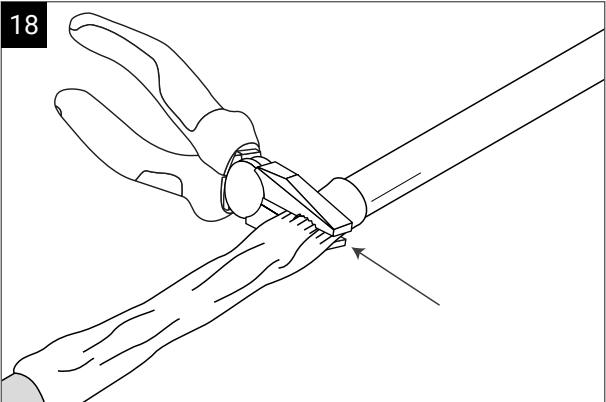

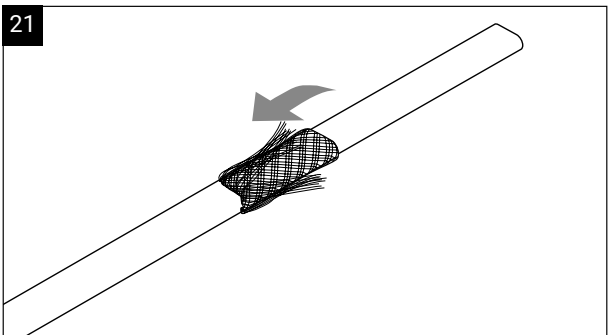
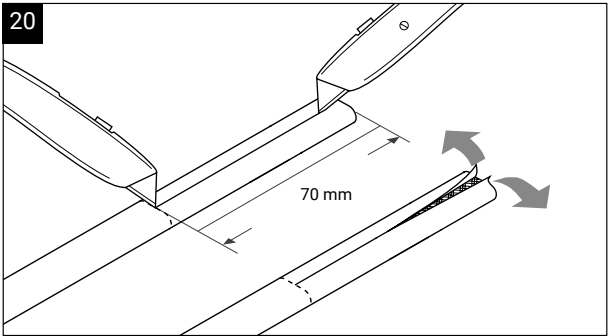
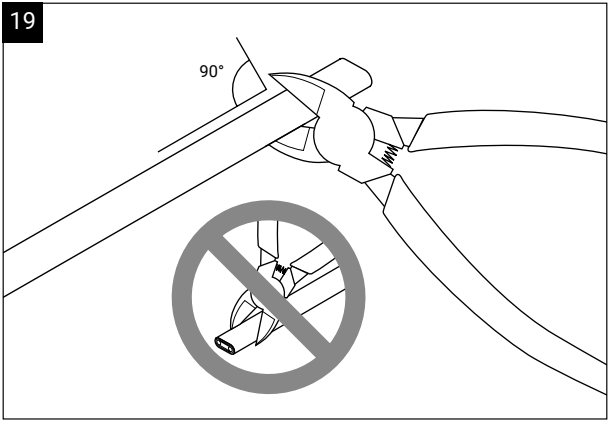

22

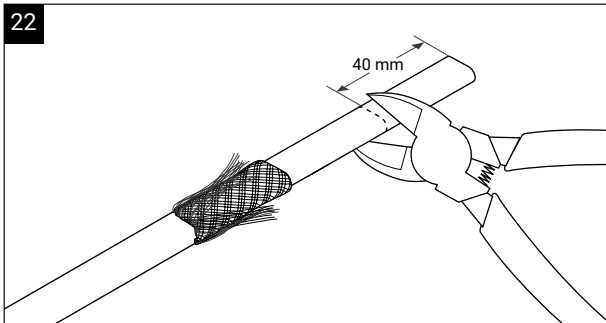

23

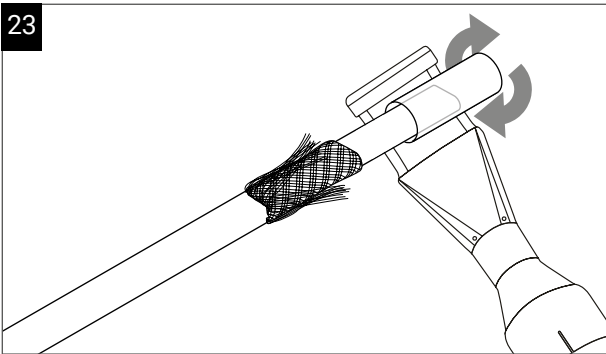

24

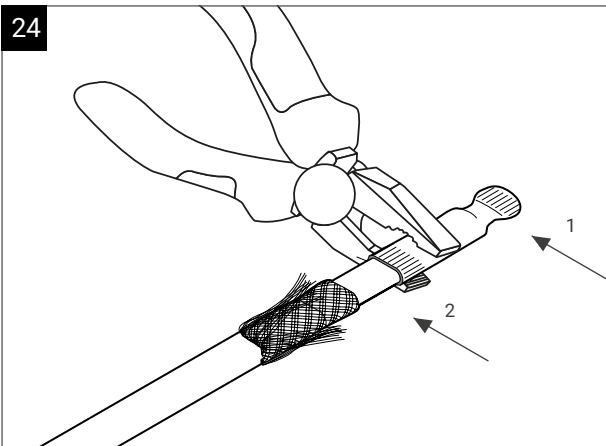

25

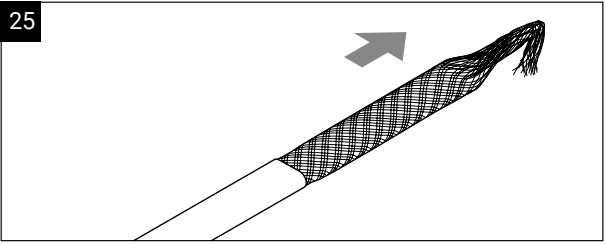

26

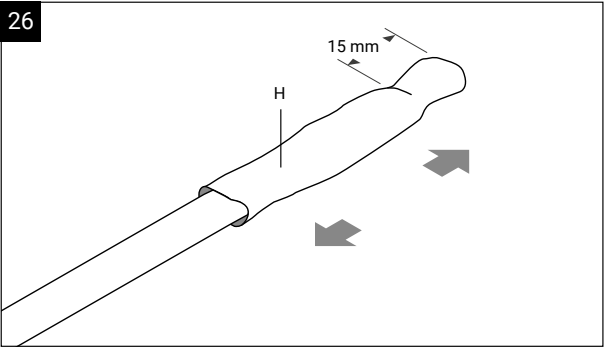

27

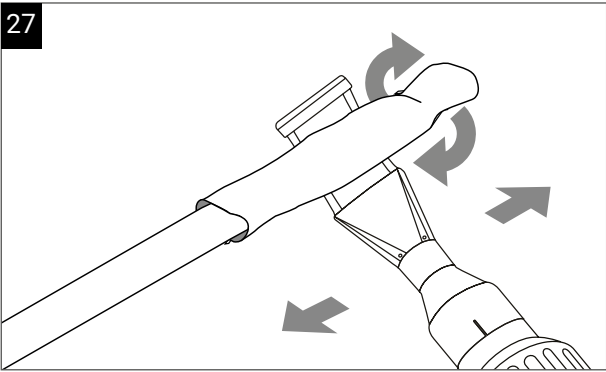

28

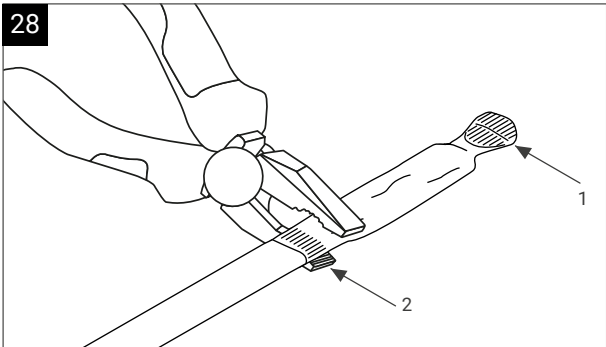



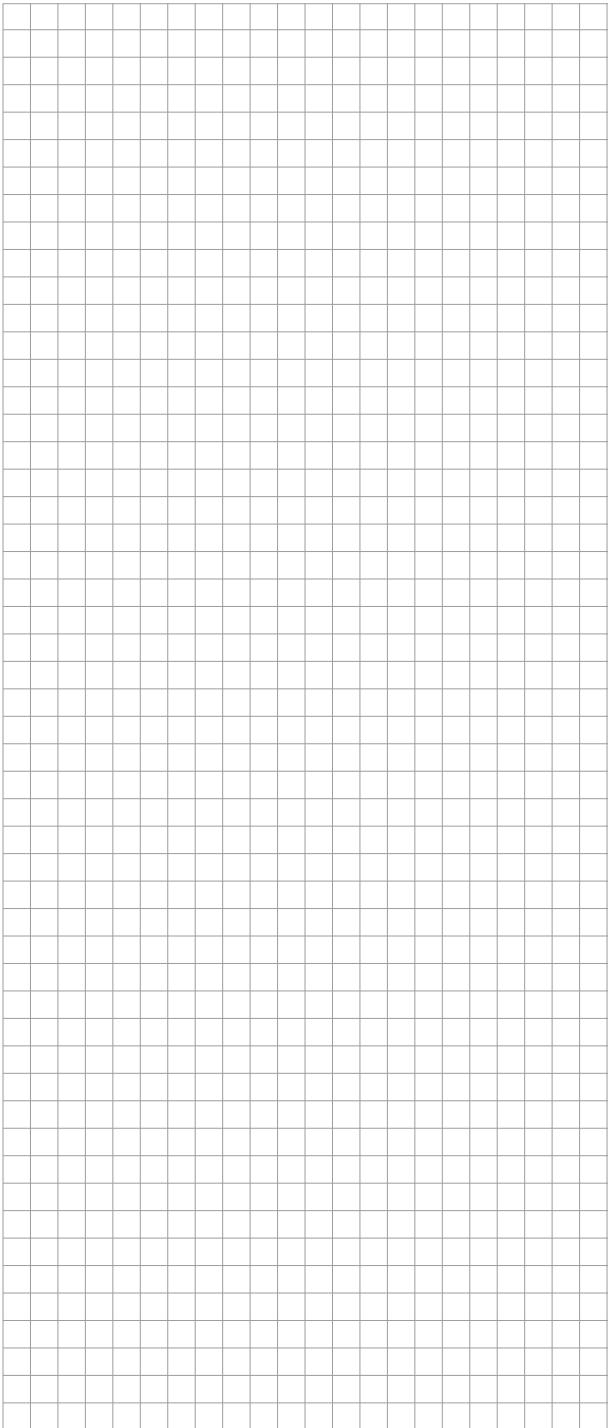

**België/Belgique**

Tel +32 16 21 35 02  
Fax +32 16 21 36 03  
salesbelux@nVent.com

**Bulgaria**

Tel +359 5686 6886  
Fax +359 5686 6886  
salesee@nVent.com

**Česká Republika**

Tel +420 606 069 618  
czechinfo@nVent.com

**Danmark**

Tel +45 70 11 04 00  
salesdk@nVent.com

**Deutschland**

Tel 0800 1818205  
Fax 0800 1818204  
salesde@nVent.com

**España**

Tel +34 911 59 30 60  
Fax +34 900 98 32 64  
ntm-sales-es@nVent.com

**France**

Tel 0800 906045  
Fax 0800 906003  
salesfr@nVent.com

**Hrvatska**

Tel +385 1 605 01 88  
Fax +385 1 605 01 88  
salesee@nVent.com

**Italia**

Tel +39 02 577 61 51  
Fax +39 02 577 61 55 28  
salesit@nVent.com

**Lietuva/Latvija/Eesti**

Tel +370 5 2136633  
Fax +370 5 2330084  
info.baltic@nVent.com

**Magyarország**

Tel +36 1 253 4617  
Fax +36 1 253 7618  
saleshu@nVent.com

**Nederland**

Tel 0800 0224978  
Fax 0800 0224993  
salesnl@nVent.com

**Norge**

Tel +47 66 81 79 90  
salesno@nVent.com

**Österreich**

Tel 0800 29 74 10  
Fax 0800 29 74 09  
salesat@nVent.com

**Polska**

Tel +48 22 331 29 50  
Fax +48 22 331 29 51  
salespl@nVent.com

**Republic of Kazakhstan**

Tel +7 495 926 1885  
Fax +7 495 926 18 86  
saleskz@nVent.com

**Россия**

Тел +7 495 926 18 85  
Факс +7 495 926 18 86  
salesru@nVent.com

**Serbia and Montenegro**

Tel +381 230 401 770  
Fax +381 230 401 770  
salesee@nVent.com

**Schweiz/Suisse**

Tel +41 (41) 766 30 80  
Fax +41 (41) 766 30 81  
infoBaar@nVent.com

**Suomi**

Puh. 0800 11 67 99  
salesfi@nVent.com

**Sverige**

Tel +46 31 335 58 00  
salesse@nVent.com

**Türkiye**

Tel +90 560 977 6467  
Fax +32 16 21 36 04  
ntm-sales-tr@nVent.com

**United Kingdom**

Tel 0800 969 013  
Fax 0800 968 624  
salesthermalUK@nVent.com



**nVent.com/RAYCHEM**

©2019 nVent. All nVent marks and logos are owned or licensed by nVent Services GmbH or its affiliates. All other trademarks are the property of their respective owners. nVent reserves the right to change specifications without notice.

RAYCHEM-IM-INST199-CCE03CR-ML-2008